

8495 GR/COMODA CAPRI

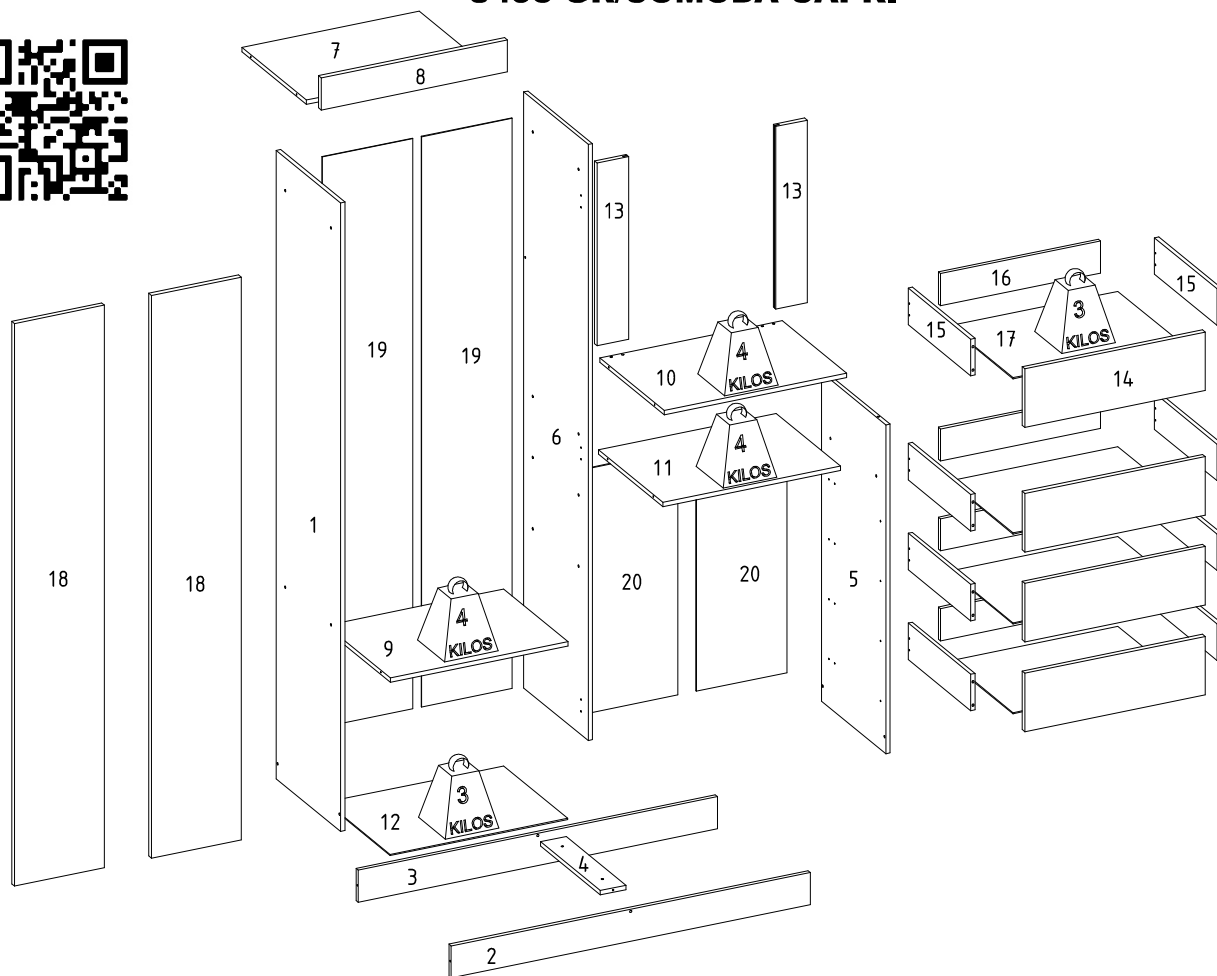



LISTA DE PEÇAS / PIECES LIST / LISTA DE PIEZAS

SEQ.	REF.	DESCRIÇÃO	DESCRIPTION	DESCRIPCIÓN	MAT.PRIMA	COMP.	LARG.	ESP.	QTD.
1	309753	LATERAL ESQ	LET SIDE	LATERAL IZQUIERDO	MDP	1720	360	12	1
2	309754	RODAPE FRONTAL	FRONT FOOTING	ZOCALO FRONTAL	MDP	1004	88	12	1
3	309755	RODAPE TRASEIRO	BACK FOOTING	ZOCALO TRASEIRO	MDP	1004	88	12	1
4	309756	TRAVA RODAPE	TRAVA RODAPE	TRAVA RODAPE	MDP	334	72	12	1
5	309757	LATERAL DIREITA	RIGHT SIDE	LATERAL DERECHO	MDP	900	360	12	1
6	309758	DIVISAO	DIVISION	DIVISORÍA	MDP	1632	360	12	1
7	309759	CHAPEU	HAT	HAT	MDP	496	360	12	1
8	309760	VISTA SUP	UPPER VIEW	VISTA SUPERIOR	MDP	520	88	15	1
9	309761	PRATELEIRA	SHELF	PRATELERA	MDP	496	360	12	1
10	309762	TAMPO	TAPSET COVER	TAMPO GAVETEIRO	MDP	510	360	12	1
11	309763	BASE DVD	TOP DVD	TAMPO DVD	MDP	496	360	12	1
12	309764	BASE	BASE	BASE	HDF	496	358	3	1
13	309765	TRAVESSA ESPELHO	MIRROR TRANSFER	TRAVESA ESPEJO	MDP	500	88	15	2
14	309766	FRENTE GAV	DRAWER FRONT	FRENTE CAJÓN	MDP	504	160	15	4
15	700296	LATERAL GAV	DRAWER LATERAL	LATERAL CAJÓN	MDP	350	100	12	8
16	309768	CONTRA FUNDO	Against the background	CONTRA FONDO	MDP	447	88	12	4
17	309769	FUNDO GAV	DRAWER BACKGROUND	FONDO DE CAJÓN	HDF	471	355	3	4
18	309770	PORTA	DOOR	PUERTA	MDP	1540	251	15	2
19	309771	FUNDO ESQUERDO	LEFT BACKGROUND	FONDO IZQUIERDO	HDF	1561	253	3	2
20	309772	FUNDO DIREITO	RIGHT BACKGROUND	FONDO DERECHO	HDF	670	253	3	2
21	309775	VISTA SUP QUADRIFLEX	UPPER VIEW	VISTA SUPERIOR	MDP	520	88	15	1

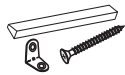
INSTRUÇÃO MONTAGEM PRODUTO
 Instructions to Assembly / Instrucciones de montaje

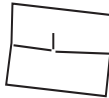
 **Separe as peças e acessórios de maneira organizada**
 Separate parts and accessories in way organized
 Separe las piezas y accesorios de manera organizada

 **Forrar o chão com o papelão das embalagens.**
 Cover the floor with the cardboard
 Cubra el suelo con la embalaje de cartón

 **É necessário 02 pessoas para montar o produto**
 02 people are required to assemble the product
 Se requieren 02 personas para ensamblar el producto

O produto deve ser a montado por um profissional qualificado
 The product must be assembly by a professional
 El producto debe ser ensamblado por un profesional calificado

Ferramentas necessárias
 (não fornecidas)

Not include tools / No herramientas



CUIDADO PARA CONSERVAÇÃO E LIMPEZA DO MÓVEL
 Care to conservation and clean / Cuidados de limpieza

Peso máximo de carga informado refere-se a objetos distribuido de maneira uniforme sobre toda área de contato da peça



The maximum load weight informed refers to objects distributed evenly over the entire contact area of the part
 Conjunto de carga máxima de peso se refiere a objetos distribuidos uniformemente sobre toda el área de contacto de la pieza de trabajo.



Não molhar o móvel e não expor em lugar úmido
 Do not wet the mobile and do not expose in a wet place
 No moje el producto y no exponer en un lugar húmedo



Não expor o móvel próximo de fontes de calor.
 Do not expose the mobile near heat sources
 no exponga cercano de fuentes de calor



Não usar produtos abrasivos.
 Do not use abrasive products.
 No utilice productos abrasivos.



Limpe com flanela limpa e seca.
 Clean with dry cloth
 Limpieza con un paño limpio y seco

LISTA DE ACESSÓRIOS E FERRAGENS / ACCESSORIES AND HARDWARE / ACCESORIOS Y HARDWARE



A- 700137-Parafuso 4,5x45 (26x)
 screw / tornillo



B- 700121-Parafuso 3,5x12 (82x)
 screw / tornillo

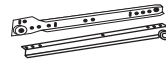

C - 700111-Corrediça (04x)
 runners / corredera



D- 700538-Cantoneira (21x)
 corner / esquina



E- 700124-Parafuso 3,5x25 (29x)
 screw / tornillo



F- 700120-Parafuso 3,0x12 (47x)
 screw / tornillo



G- 700435-Suporte 'U' fechado (02x)
 closed U support / soporte U cerrado



H- 700547-Junção (06x)
 junction / juncion



I- 700542-Cavilha 6x30 (18x)
 peg / cerrojo



J- 700300-Bastão madeira (01x)
 wooden rail / barra madera



K- 700297-Perfil H (01x)
 handle / manija



L- 700171-Puxador 250 mm (06x)
 Handle / Manija



M- 700395-Dobradiça (06x)
 700390 - Calço (06x)
 hinge / bisagra



N- 700157-Prego (87x)
 nail / clavo



O- 700230-Pé PVC (04x)
 PVC foot / Pie de PVC



P - 700516-Sache cola 20g (1x)
 Glue / Goma



Q - 700294-Espelho (1x)
 mirror / espejo



R- 700131-Parafuso 4,0x20 (04x)
 screw / tornillo



S- 700298-Perfil H (01x)
 handle / manija













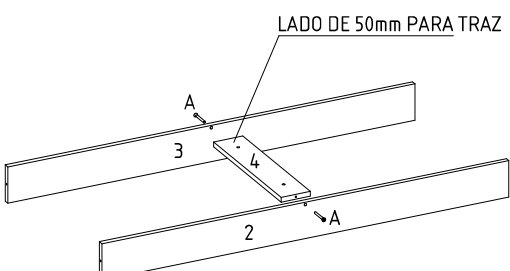

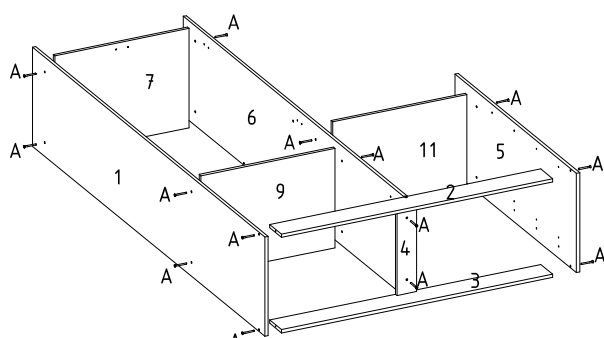



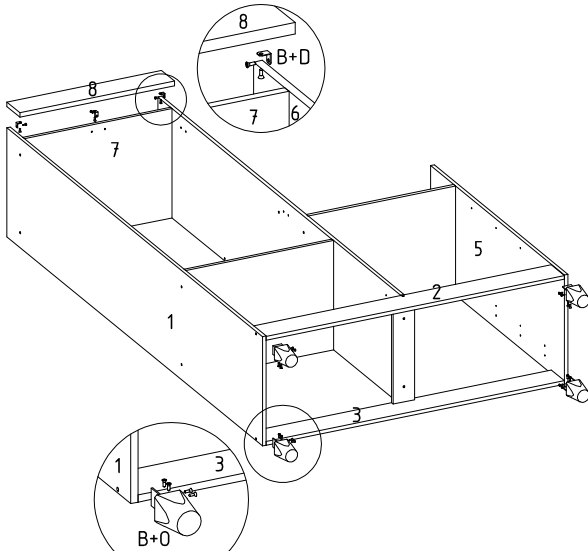

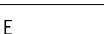

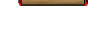

T- 700130-Parafuso 4,0x16 (1x)
 screw / tornillo

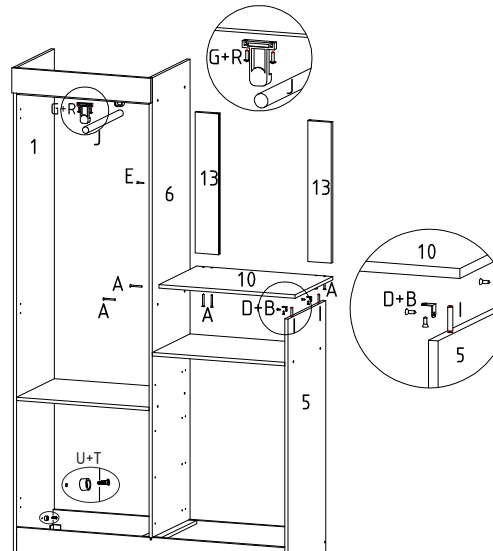

U - 700441-Suporte prateleira(1x)
 Support/apoyo

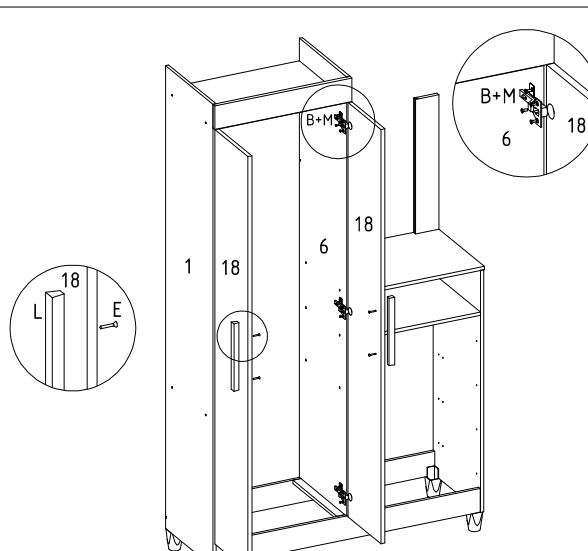
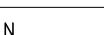

V - 700419-Tapa furo(12x)
 cover hole/ agujero de la cubierta

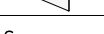
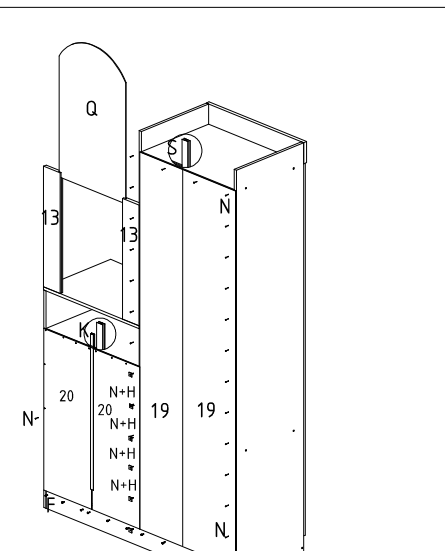
01° PASSO	Fixar as peças 2 e 3 na peça 4	02° PASSO	Fixar as peças 1,5 e 6 nas peças 2,3 e 4. Fixar as peças 7,9 e 11 nas peças 1,5 e 6
01° STEP	Secure parts 2 and 3 in part 4	02° STEP	Fix parts 1.5 and 6 on parts 2,3 and 4. Fix parts 7, 9 and 11 on parts 1,5 and 6
01° PASO	Fijar las piezas 2 y 3 en la pieza 4	02° PASO	Fijar las piezas 1,5 y 6 en las piezas 2,3 y 4. Hacer las piezas 7,9 y 11 en las piezas 1,5 y 6
			
03° PASSO	Fixar a peça 8 na peça 7. Fixar o acessório 0 nas peças 1,2,3 e 5	04° PASSO	Fixar as peças 13 na peça 10, peça 10 nas peças 6 e 5. Fixar o acessório G na peça 7
03° STEP	Attach part 8 to part 7. Attach accessory 0 to parts 1,2,3 and 5	04° STEP	Fasten parts 13 on part 10, part 10 on parts 6 and 5. Attach attachment G on part 7
03° PASO	Fijar la pieza 8 en la pieza 7. Hacer el accesorio 0 en las piezas 1,2,3 y 5	04° PASO	Fijar las piezas 13 en la pieza 10, pieza 10 en las piezas 6 y 5. Fijar el accesorio G en la pieza 7
  		       	
05° PASSO	Fixar as peças 18 nas peças 1 e 6, fixar o acessório L nas peças 18	06° PASSO	Utilizar as ferragens N,H,K,S e B para fixar as peças 19 e 20
05° STEP	Fasten parts 18 on parts 1 and 6, attach accessory L on parts 18	06° STEP	Use the hardware N, H, K, S and B to fix parts 19 and 20
05° PASO	Fijar las piezas 18 en las piezas 1 y 6, fijar el accesorio L en las piezas 18	06° PASO	Utilizar los herrajes N, H, K, S y B para fijar las piezas 19 y 20
   		     	

07° PASSO	Fixar as peças 15 na peça 14	08° PASSO	Fixar a peça 16 nas peças 15,fixar o acessório L na peça 14
07° STEP	Fasten parts 15 to part 14	08° STEP	Fasten piece 16 to pieces 15, attach accessory L to piece 14
07° PASO	Fijar las piezas 15 en la pieza 14	08° PASO	Fijar la pieza 16 en las piezas 15, fijar el accesorio L en la pieza 14
B		E	
D		L	
I			
P			
-			
09° PASSO	Fixar a peça 17 nas peças 15 e 16,fixar o acessório C nas peças 17 e 15	10° PASSO	
09° STEP	Fasten piece 17 on parts 15 and 16, attach accessory C on parts 17 and 15	10° STEP	
09° PASO	Fijar la pieza 17 en las piezas 15 y 16, fijar el accesorio C en las piezas 17 y 15	10° PASO	
N		-	
F		-	
C		-	
		-	

ASPECTO FINAL DO PRODUTO
FINAL ASPECT OF PRODUCT
ASPECTO FINAL DEL PRODUCTO

